

# SANDHOPPER ONE DESIGN CLASS

# MEASUREMENT DIAGRAM

N.B. Minimum sailcloth weight of main and head sails = 185 gms. per sq. meter.

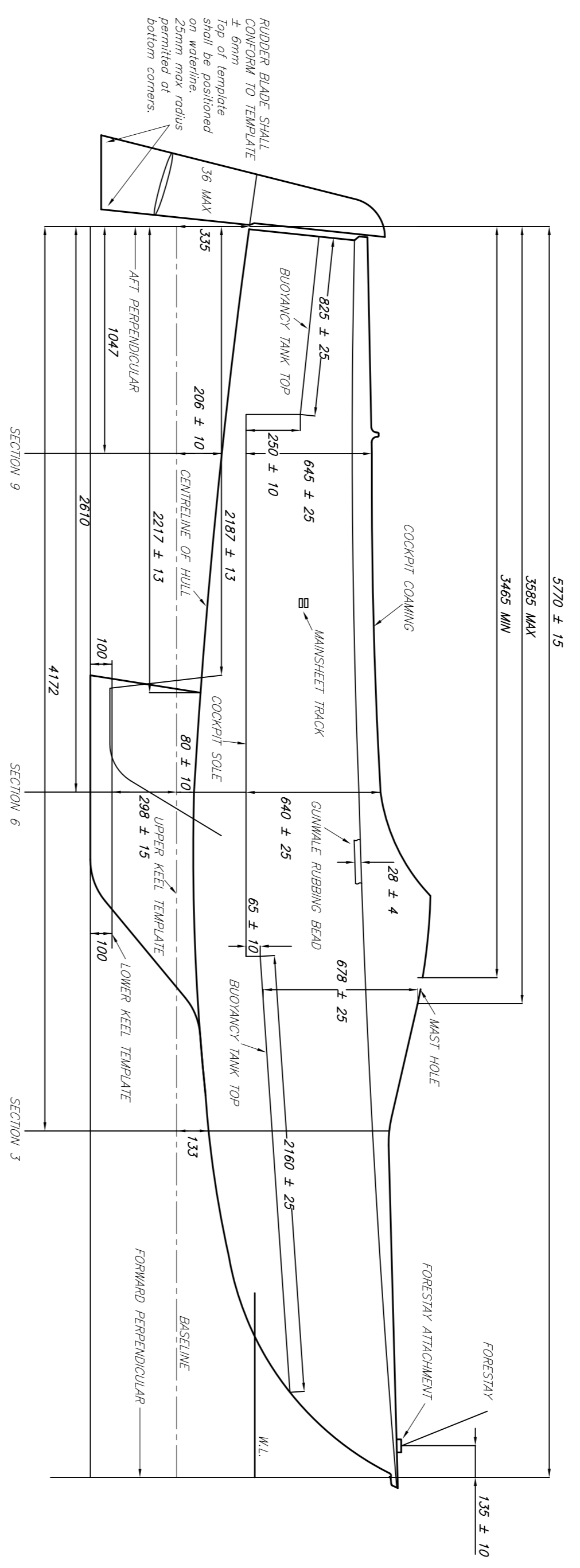
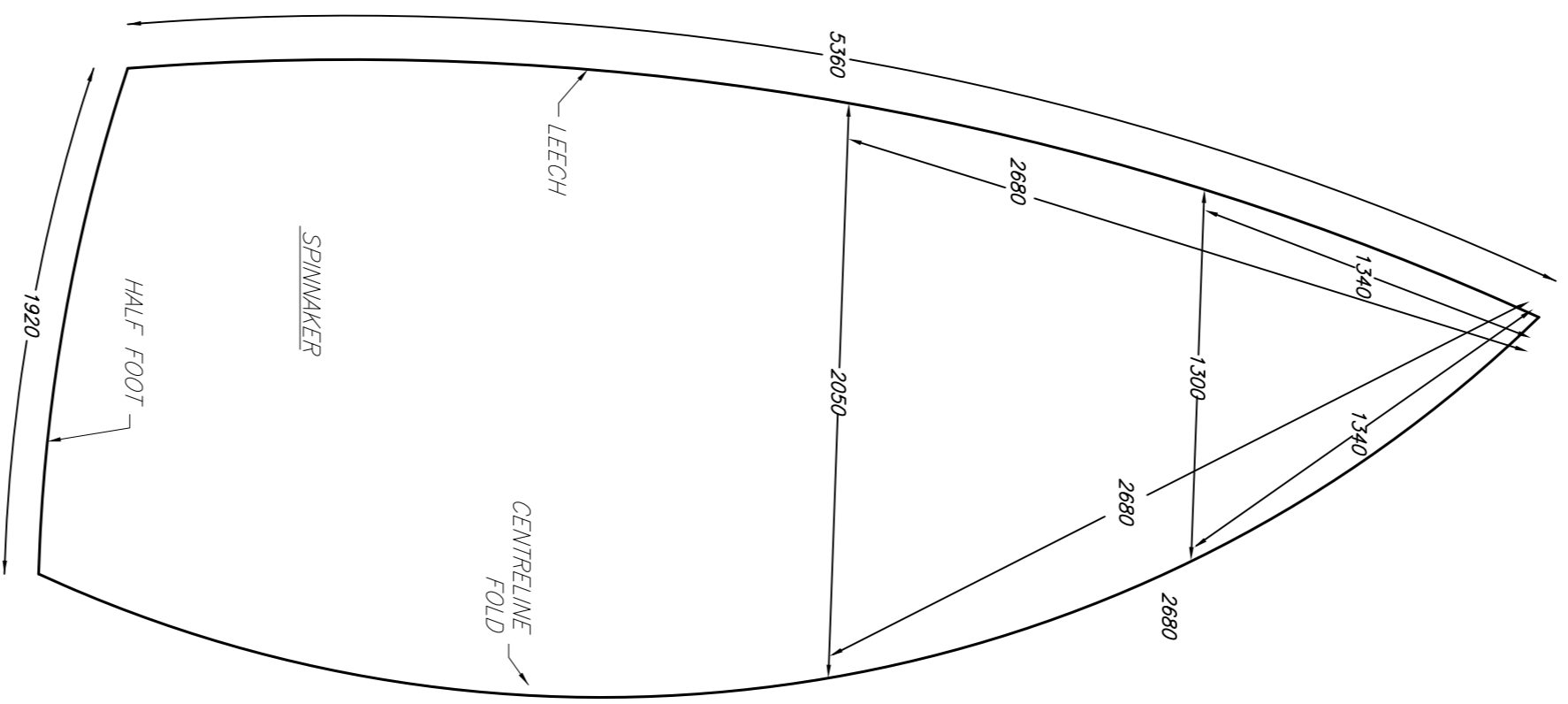
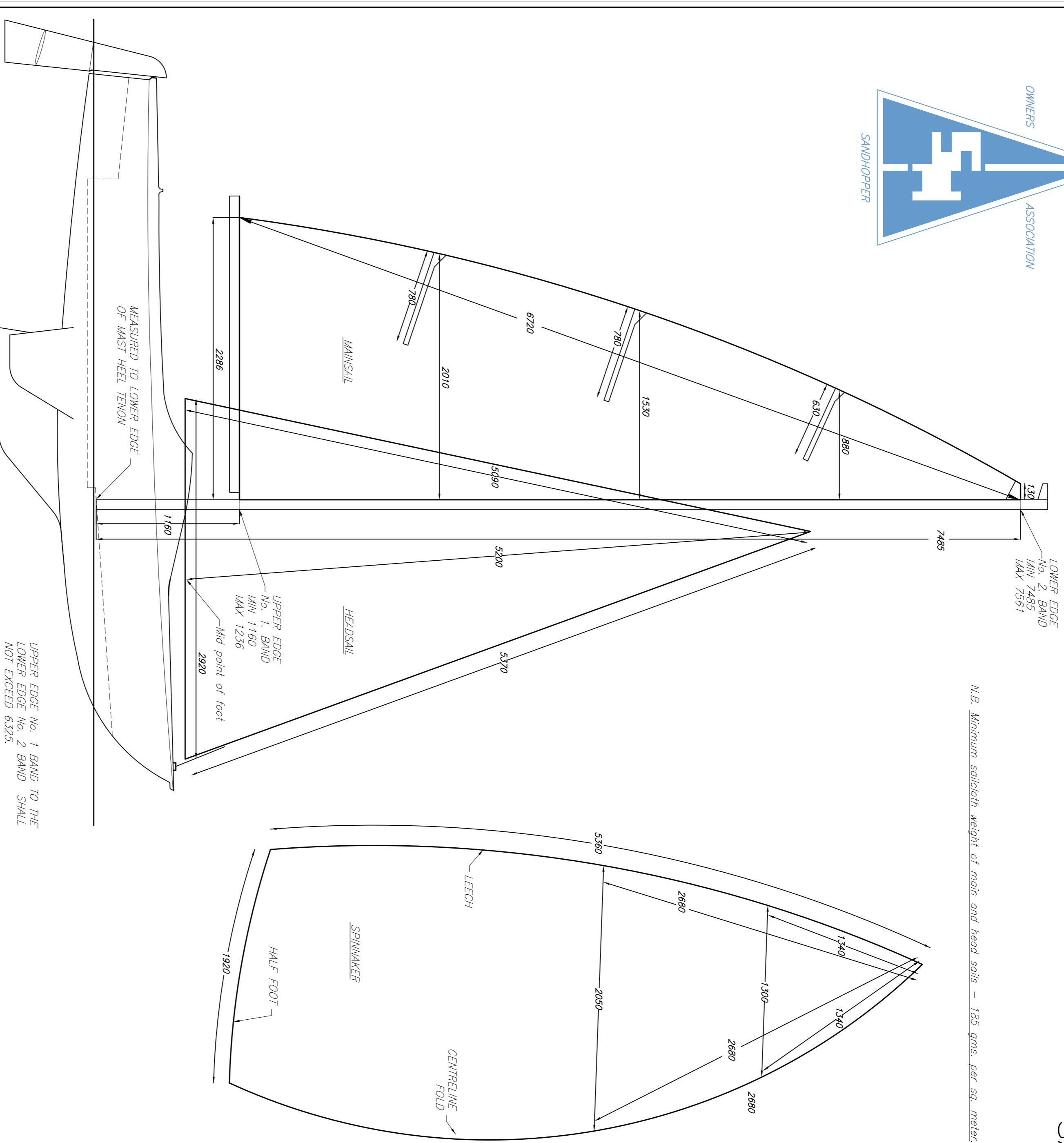

RUBBER BALE SHALL BE 10mm ± 5mm  
Top of template shall be positioned 25mm max radius permitted at bottom corners.

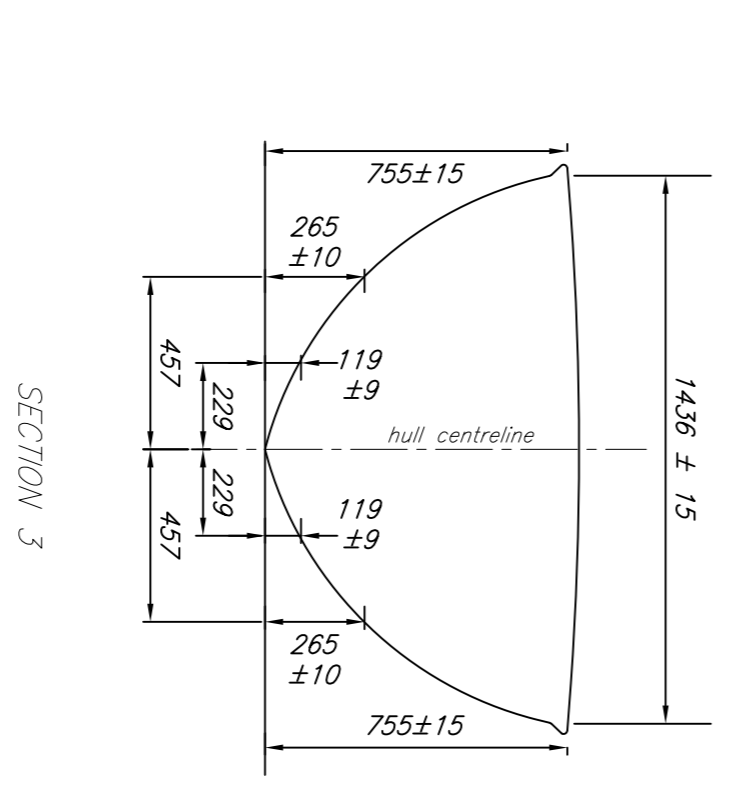
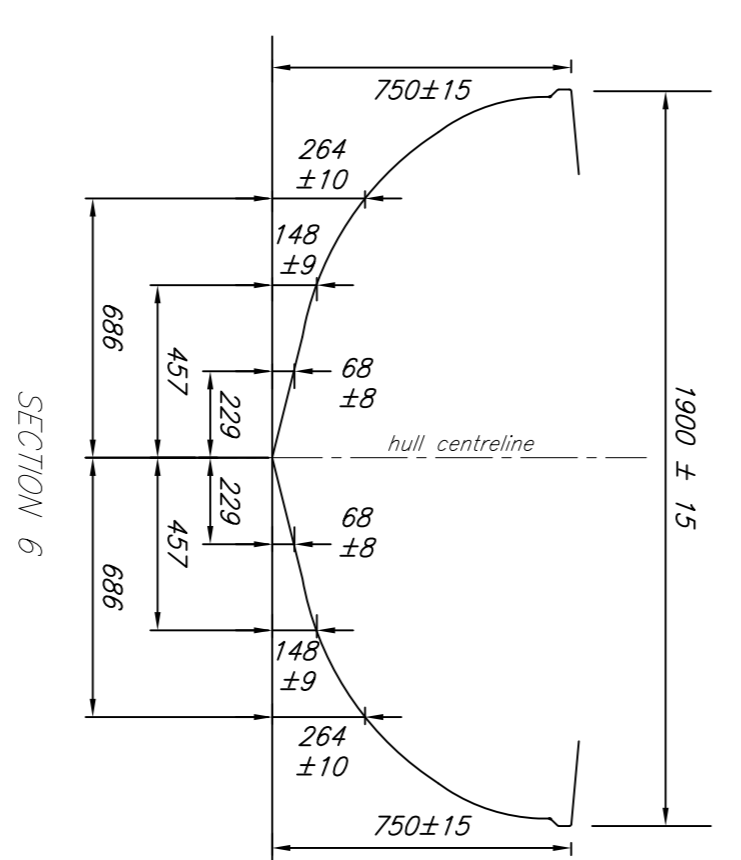
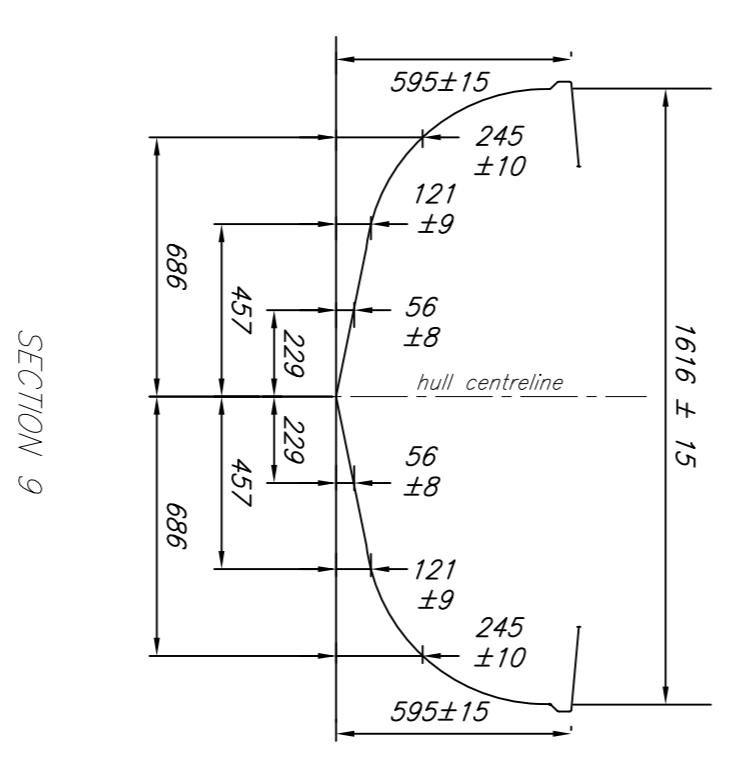

SAIL MEASUREMENT PLAN  
SCALE 1:25

HULL MEASUREMENT PLAN  
SCALE 1:20

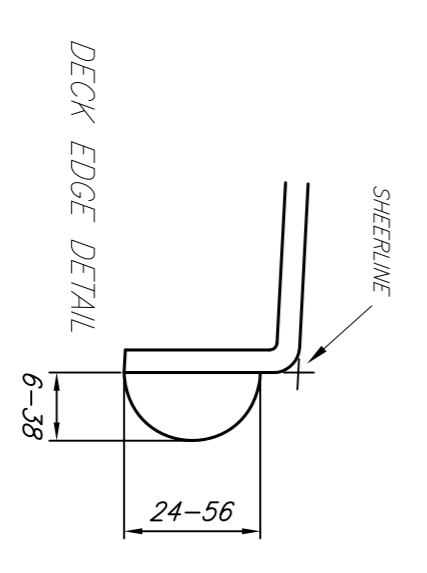

REVISION 1st JANUARY 1973  
REVISED SEPTEMBER 1997  
AMENDED JANUARY 2009